

STRINGING BLOCK - SPRING GATE

⚠ WARNING

Cancer and Reproductive Harm: www.P65Warnings.ca.gov



KEY FEATURES

- ✓ Lightweight, durable aluminum
- ✓ Low-friction bearings
- ✓ Crossarm bracket and ball clevis attachments also available

The ZAB4344 is our spring gate 7" aluminium distribution stringing block. This block is used for the transfer or replacement of aerial conductors. Its low friction bearings deliver high efficiency, which helps to maximise stringing distances whilst minimising pulling tensions and reducing the load on stringing equipment.

The gate has been designed for use with hot stick and/or hand operation and can be locked in the open position to allow the linesman to freely remove the conductor. Once the gate is released, the gate closes and locks automatically. The ZAB4344 has three mounting positions and is compatible with Slingco's crossarm bracket options and ball clevis attachments.



GET IN TOUCH



1 888 685 9478



sales@slingcoamerica.com

STRINGING BLOCK - SPRING GATE

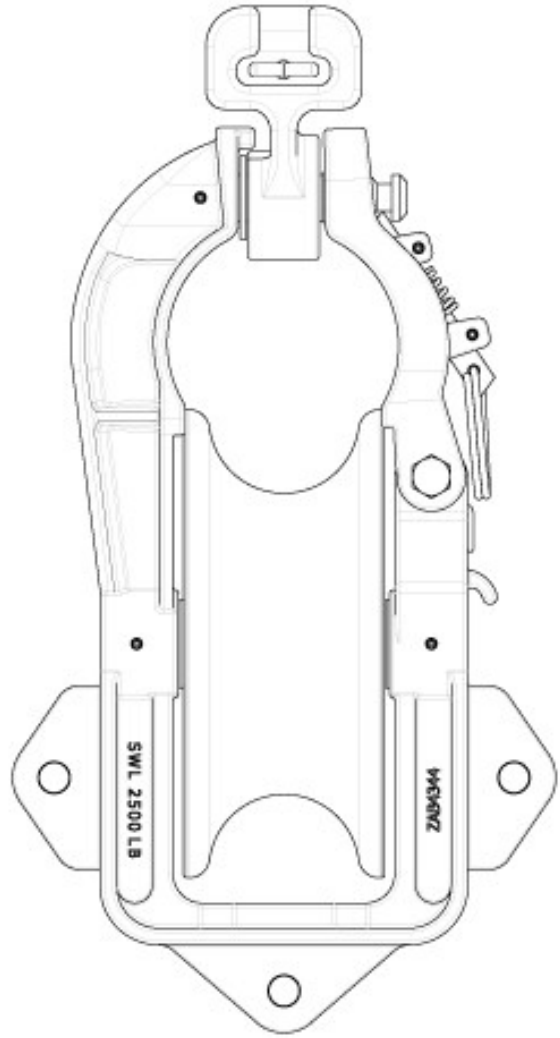
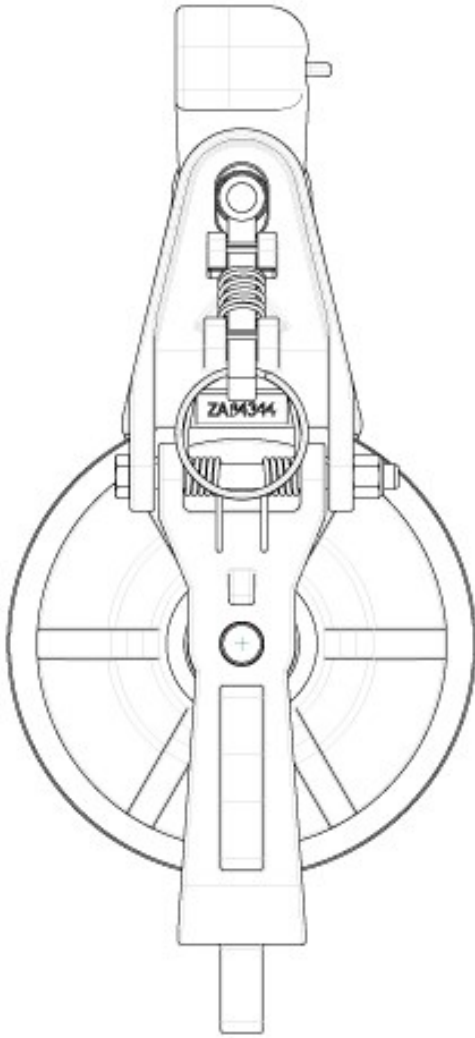

Slingco Part No.	Description	Weight (lb)	Weight (kg)	WLL (lb)	WLL (kg)	Height (in)	Height (mm)	Sheave Size (in)	Sheave Size (mm)	Bottom of Groove (in)	Bottom of Groove (mm)	Groove Radius (in)	Groove Radius (mm)
ZAB4344	7" Spring Open Aluminum Distribution Block	9.2	3.76	2,500	1,134	15.344	384.2	7	177.8	4.5	114.3	2.25	57.15

This information is for marketing purposes only. The details contained herein is presented as general information and no representation or warranty is expressly or impliedly given as to its accuracy, completeness or correctness. It does not constitute part of a legal offer or contract. For technical specifications, please contact Slingco America, Inc.

Dimensions

The figures shown are indicative only. Fully dimensioned data-sheets are available on request. Nominal figures/actuals are as per data-sheet with tolerances of +/-10%. Please contact us if you have any questions.

Range dimension overlaps If the cable, rope or hose you have lies where ranges overlap, e.g. 1" when sizing is 0.5-1.00 and 1.00-1.5 we recommend that you select your cable grip to achieve break load first. If tensile strengths are equal or both adequate, choose the smaller of the two. Please contact us if you have any questions.



GET IN TOUCH



1 888 685 9478



sales@slingcoamerica.com