



# Hydraulic Hose Harness

Safety restraining system  
designed to prevent whipping



## HYDRAULIC HOSE HARNESS

The Slingco Hydraulic Hose Harness limits the whip or 'travel' of a pressurised hose in the event of it becoming detached from its fitting.

The damage caused by a violently whipping hose, especially one operating under high pressure, can pose severe health and safety concerns - not to mention financial and legal ramifications - for any company. The Slingco Hydraulic Hose Harness (H3) addresses this concern by limiting the whip or 'travel' of the pressurised hose if it breaks free from its hose fitting.

### Features and benefits

- Designed to prevent whipping in the event of a pressurised hose becoming detached from the fitting
- Helps prevent injury to operators and damage to equipment near a hose failure
- Ideal for use in Oil and Gas applications, mining and manufacturing for pressurised fluid and air hoses
- Double eye, double weave mesh construction, with reinforced thimble eyes
- High strength galvanised steel

Note: all proper health and safety procedures must be carried out in addition to the use of an H3 Harness.

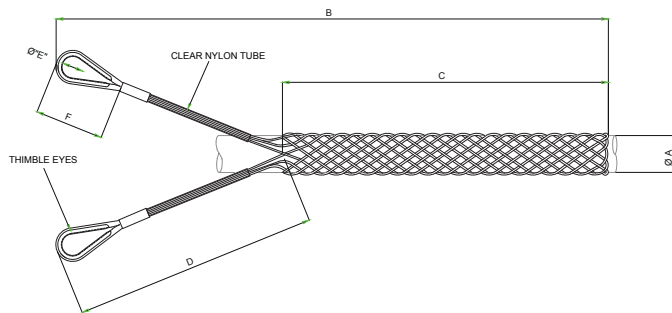

- ✓ Helps prevent injury to operators and damage to equipment near a hose failure
- ✓ Ideal for use in Oil and Gas applications, mining and manufacturing for pressurised fluid and air hoses
- ✓ Addresses both health and safety concerns and potential financial and legal ramifications

Slingco part no.	Ø A Nominal	Range	Lattice weave	B Length	C Length	D Length	Ø E	F Length	Approximate Break Load
<b>DOUBLE THIMBLE EYE DOUBLE WEAVE GALVANISED STEEL</b>									
ZCS5363	32mm 1.25"	25 - 38mm 1.0 - 1.5"	Double	864mm 34"	660mm 26"	203mm 8"	25.4mm 1.0"	68mm 2.67"	4,911 kgs. 11,000 lbs
ZCS5364	51mm 2.0"	38 - 63mm 1.5 - 2.5"	Double	1270mm 50"	1016mm 40"	254mm 10"	25.4mm 1.0"	68mm 2.67"	8,928 kgs 20,000 lbs
ZCS5365	76mm 3.0"	63 - 89mm 2.5 - 3.5"	Double	1321mm 52"	1067mm 42"	254mm 10"	25.4mm 1.0"	68mm 2.67"	9,821 kgs 22,000 lbs
ZCS5366	102mm 4.0"	89 - 114mm 3.5 - 4.5"	Double	1422mm 56"	1118mm 44"	305mm 12"	25.4mm 1.0"	68mm 2.67"	12,053 kgs 27,000 lbs
ZCS5367	127mm 5.0"	114 - 140mm 4.5 - 5.5"	Double	1524mm 60"	1219mm 48"	305mm 12"	25.4mm 1.0"	68mm 2.67"	13,839 kgs 31,000 lbs

Lengths B and C when on nominal mandrel Ø A